No. 34 IACS Procedural Requirement on Application of the IMO Performance Standard for Protective Coatings (PSPC), Resolution MSC.215(82), under IACS Common Structural Rules for Bulk Carriers and Oil Tankers

(Dec 2006)
(Corr.1 Oct 2007)
(Rev.1 Jan 2008)

Table of Contents

Introduction

1. IACS Procedure for Coating System Approval
2. IACS Procedure for Assessment of Coating Inspectors' Qualifications
3. IACS Procedure for Inspection Agreement (the PSPC 3.2)
4. IACS Procedure for Verification of Application of the PSPC
5. IACS Procedure for Coating Technical File Review
6. IACS Procedure for review of Quality Control of Automated Shop Primer plants
7. IACS Procedure for review of Coating Technical Specifications

Annex 1	Work Procedures for Uniform Implementation of IMO PSPC by the EG/Coating
Annex 2	Unified Interpretations
Annex 3	Coating Manufacturers

Note:

1. The "contracted for construction" date means the date on which the contract to build the vessel is signed between the prospective owner and the shipbuilder. For further details regarding the date of "contract for construction", refer to IACS Procedural Requirement (PR) No. 29.
2. Changes introduced in Revision 1 shall be applied by Members and Associate to requests for approvals of coating systems and coating manufacturers received from 1 January 2008 and on ships subject to the IACS Common Structural Rules (CSR) for Bulk Carriers and for Oil Tankers which are contracted for construction on or after 1 January 2008 and until the date of application referred to in para.1 of SOLAS Chapter II-1, Part A-1, Reg.3-2, as adopted by resolution MSC.216(82).

No.**34**

(cont'd)

Introduction

This Procedural Requirement shall be applied by IACS Societies for application of the IMO PSPC to ships subject to the IACS Common Structural Rules (CSR) for Bulk Carriers and for Oil Tankers which are contracted for construction on or after 8 December 2006 and until the date of application referred to in para.1 of SOLAS Chapter II-1, Part A-1, Reg.3-2, as adopted by resolution MSC.216(82).

The objective of this Procedural Requirement is to ensure uniform understanding and application of the requirements of the IMO PSPC.

References made to "IACS Society" or "Society" should be read as including IACS Members and Associate.

This Procedural Requirement contains:

- uniform requirements that shall be applied by all IACS Societies, and
- work procedures for the IACS Expert Group on Coating (EG/Coating) in developing consistent answers and common interpretations relating to the IMO PSPC. Refer to Annex 1.

This IACS Procedural Requirement ~~is to~~ shall be read in conjunction with the IMO Performance Standard for Protective Coatings (PSPC), Resolution MSC.215(82). Application of the referenced international standards footnoted therein is mandatory under this Procedural Requirement.

1. IACS Procedure for Coating System Approval

Type Approval Certificate showing compliance with the PSPC section 5 shall be issued if the results of either method A+D, or B+D, or C+D are found satisfactory by the Society.

The Type Approval Certificate shall indicate the Product and the Shop Primer tested. The certificate shall also indicate other type approved shop primers with which the product may be used which have under gone the cross over test in a laboratory meeting the requirements in section 1.1 of this procedure.

The documents required to be submitted are identified in the following sections, in addition for all type approvals the following documentation is required:

Technical Data Sheet showing all the information required by PSPC 3.4.2.2.

Winter and summer type coating are considered different unless infrared (IR) identification and specific gravity (SG) demonstrates that they are the same.

Method A: Laboratory Test

1.1 Coating pre-qualification test shall be carried out by the test laboratory which is recognized by the Society and the test laboratory shall meet the requirements set out in IACS UR Z17.

1.2 Results from satisfactory pre-qualification tests (PSPC table 1, paragraph 1.3 of the PSPC) of the coating system shall be documented and submitted to the Society.

1.3.1 Type Approval tests shall be carried out for the epoxy based system with the stated shop primer in accordance with the PSPC Annex 1. If the tests are satisfactory, a Type

No. 34

(cont'd)

Approval Certificate will be issued to include both the epoxy and the shop primer. The Type Approval Certificate will allow the use of the epoxy either with the named shop primer or on bare prepared steel.

1.3.2 An epoxy based system may be used with shop primers other than the one with which it was originally tested provided that, the other shop primers are approved as part of a system, PSPC Table 1.2.3 and Table 1.3.2, and have been tested to Annex 1, Appendix 1, 1.7, which is known as the "Crossover Test". If the test or tests are satisfactory, a Type Approval Certificate will be issued. In this instance the Type Approval Certificate will include the details of the epoxy and a list of all shop primers with which it has been tested that have passed these requirements. The Type Approval Certificate will allow the use of the epoxy with all the named shop primers or on bare prepared steel.

1.3.3 Alternatively the epoxy can be tested without shop primer on bare prepared steel to the requirements of the PSPC Annex 1. If the test or tests are satisfactory, a Type Approval Certificate will be issued. The Type Approval Certificate will just record the epoxy. The certificate will allow the use of the epoxy on bare prepared steel only. If in addition, crossover tests are satisfactorily carried out with shop primers which are approved as part of a system, the Type Approval Certificate will include the details of shop primers which have satisfactorily passed the crossover test. In this instance the Type Approval Certificate will allow the use of the epoxy based system with all the named shop primers or on bare prepared steel.

1.3.4 The Type Approval Certificate is invalid if the formulation of either the epoxy or the shop primer is changed. It is the responsibility of the manufacturer to inform class immediately of any changes to the formulation.

1.3.5 Approvals granted according to previous versions of PR 34, before the date of implementation of the latest revision, remain valid as stated in the respective certificate. Renewal of certificates must be done in compliance with the latest version of PR 34.

Method B: 5 years field exposure

1.34 Coating manufacturer's records, which shall at least include the information indicated in 1.4.1, shall be examined to confirm coating system has 5 years field exposure, and the current product is the same as that being assessed.

1.4.1 Manufacturer's Records

- Original application records
- Original coating specification
- Original technical data sheet,
- Current formulation's unique identification (Code or number)
- If the mixing ratio of base and curing agent has changed, a statement from the manufacturer confirming that the composition mixed product is the same as the original composition. This shall be accompanied by an explanation of the modifications made.
- Current technical data sheet for the current production site
- SG and IR identification of original product
- SG and IR identification of the current product
- If original SG and IR cannot be provided then a statement from the manufacturer confirming the readings for the current product are the same as those of the original.

1.5 Either class survey records from a class society or a A joint (coating manufacturer / Society) survey of all ballast tanks of a selected vessel is to be carried out for the purpose of

No. 34

(cont'd)

verification of compliance with the requirements of sections 1.3 and 1.7. The reporting of the coating condition in both cases shall be in accordance with the IACS Recommendation 87, section 2.

1.6 The selected vessel is to have ballast tanks in regular use, of which:

- At least one tank is approximately 2000 m³ or more in capacity
- At least one tank shall be adjacent to a heated tank and
- At least one tank contains an underdeck exposed to the sun.

1.7 In the case that the selected vessel does not meet the requirements in 1.56 then the limitations shall be clearly stated on the type approval certificate. For example, the coating cannot be used in tanks adjacent to heated tanks or underdeck or tanks with volume greater than the size surveyed.

1.8 In all cases of approval by Method B, the shop primer shall be removed prior to application of the approved epoxy based system coating, unless it can be confirmed that the shop primer applied during construction, is identical in formulation to that applied in the selected vessel used as a basis of the approval.

1.9 All ballast tanks shall ~~are to~~ be in "GOOD" condition, without touch up or repair in the prior 5 years.

1.9.1 "Good" is defined as: *Condition with spot rusting on less than 3% of the area under consideration without visible failure of the coating. Rusting at edges or welds, must be on less than 20% of edges or welds in the area under consideration.*

1.9.2 Examples of how to report coating conditions with respect to areas under consideration should be as those given in IACS Recommendation 87*.

1.10 If the applied NDFT is greater than required by the PSPC, the applied NDFT will be the minimum to be applied during construction. This will be reported prominently on the Type Approval Certificate.

1.11 If the results of the inspection are satisfactory, a Type Approval Certificate shall be issued to include both the epoxy based system and the shop primer. The Type Approval Certificate shall allow the use of the epoxy based system either with the named shop primer or on bare prepared steel. The Type Approval Certificate shall reference the inspection report which will also form part of the Coating Technical File.

1.12 The Type Approval Certificate is invalid if the formulation of either the epoxy based system or the shop primer is changed. It is the responsibility of the manufacturer to inform class immediately of any changes to the formulation.

Method C: Existing Marintek B1 Approvals

1.813 Epoxy based system Coatings Systems with existing satisfactory Marintek test reports minimum level B1 including relevant IR identification and SG, issued before 8 December 2006 can be accepted. If original SG and IR documentation cannot be provided, then a statement shall be provided by the manufacturer confirming that the readings for the current product are the same as those of the original.

* IACS Recommendation 87 is not mandatory.

**No.
34**
(cont'd)

1.14 The Marintek test report with IR and SG information shall be reviewed and if satisfactory, a Type Approval certificate shall be issued. The certificate shall record the report reference and the shop primer used. The Type Approval Certificate shall allow the use of the epoxy based system either with the named shop primer, unless there is evidence to indicate that it is unsuitable, or on bare prepared steel.

1.15 The epoxy based system approved by this method may be used with other shop primers if satisfactory crossover tests are carried out with shop primers which are approved as part of a system, see 1.3.2. In this instance, the Type Approval Certificate will include the details of the epoxy based system and a list of all shop primers which have passed these requirements. The Type Approval Certificate will allow the use of the epoxy based system with all the named shop primers or on bare prepared steel.

1.16 Such coatings shall be applied in accordance with Table 1 of the PSPC rather than the application conditions used during the approval test which may differ from the PSPC, unless these are more stringent than Table 1 of the PSPC, for example if the NDFT is higher.

1.17 The Type Approval Certificate is invalid if the formulation of either the epoxy based system or the shop primer is changed. It is the responsibility of the manufacturer to inform class immediately of any changes to the formulation.

Method D: Coating Manufacturer

1.18 The coating/shop primer manufacturer shall meet the requirements set out in IACS UR Z17 paragraphs 4, 5, 6 and 7, (except for 4.6) and Annex 3 of PR34, which shall be verified by the Society.

1.19 In the case that a manufacturer wishes to have products which are manufactured in different locations under the same name, then IR identification and SG shall be used to demonstrate that they are the same coating, or individual approval tests will be required for the paint manufactured in each location.

1.20 The Type Approval Certificate is invalid if the formulation of either the epoxy based system or the shop primer is changed. It is the responsibility of the manufacturer to inform class immediately of any changes to the formulation. Failure to inform class of an alteration to the formulation will lead to cancellation of the certificates for that manufacturer's products.

2. IACS Procedure for Assessment of Coating Inspectors' Qualifications

2.1 Coating inspectors required to carry out inspections in accordance with the IMO PSPC section 6 shall be qualified to NACE Coating Inspector Level 2, FROSIO Inspector Level III, or an equivalent qualification. Equivalent qualifications are described in 2.3 below.

2.2 However, only coating inspectors with at least 2 years relevant coating inspector experience and qualified to NACE Coating Inspector Level 2 or FROSIO Inspector Level III, or with an equivalent qualification, can write and/or authorise procedures, or decide upon corrective actions to overcome non-compliances.

2.3 Equivalent Qualification:

2.3.1 **Equivalent** qualification is the successful completion, as determined by course tutor, of an approved course.

**No.
34**

(cont'd)

2.3.1.1 The **course tutors** shall be qualified with at least 2 years relevant experience and qualified to NACE Coating Inspector Level 2 or FROSIO Inspector Level III, or with an equivalent qualification.

2.3.1.2 **Approved Course:** A course that has a syllabus based on the issues associated with the PSPC including the following:

- Health Environment and Safety
- Corrosion
- Materials and design
- International standards referenced in PSPC
- Curing mechanisms
- Role of inspector
- Test instruments
- Inspection Procedures
- Coating specification
- Application Procedures
- Coating Failures
- Pre-job conference
- MSDS and product data sheet review
- Coating technical file
- Surface preparation
- Dehumidification
- Waterjetting
- Coating types and inspection criteria
- Specialized Application Equipment
- Use of inspection procedures for destructive testing and non destructive testing instruments.
- Inspection instruments and test methods
- Coating inspection techniques
- Cathodic protection
- Practical exercises, case studies.

Examples of approved courses may be internal courses run by the coating manufacturers or shipyards etc.

2.3.1.3 Such a course shall have an acceptable measurement of performance, such as an examination with both theoretical and practical elements. The course and examination shall be approved by the Society.

2.3.2 Equivalent qualification arising from practical experience: An individual may be qualified without attending a course where it can be shown that the individual:

- has a minimum of 5-years practical work experience as a coating inspector of ballast tanks during new construction within the last 10 years, and
- has successfully completed the examination given in 2.3.1.3.

2.4 **Assistant Inspectors**

2.4.1 If the coating inspectors requires assistance from other persons to do the part of the inspections under the coating inspector's supervision, those persons shall be trained to the coating inspector's satisfaction.

**No.
34**
(cont'd)

2.4.2 Such training should be recorded and endorsed either by the inspector, the yard's training organisation or inspection equipment manufacturer to confirm competence in using the measuring equipment and confirm knowledge of the measurements required by the PSPC.

2.4.3 Training records shall be available for verification if required.

3. IACS Procedure for Inspection Agreement (the PSPC 3.2)

3.1 The procedure for inspection of surface preparation and coating processes shall be agreed upon, between the shipowner, the shipyard and coating manufacturer. It should be presented by the shipyard to the Society for review and as a minimum shall comply with the PSPC. It shall be included in the Coating Technical File, the qualifications of the coating inspector(s). Where more than one coating inspector will be used then their areas of responsibility shall be identified. (For example multiple construction sites).

3.2 Any deviations in the procedure relative to the PSPC noted during the review shall be raised with the shipyard, which is responsible for identifying and implementing the corrective actions.

3.3 A class certificate ~~is~~ shall not ~~to~~ be issued until all required corrective actions have been closed out to the satisfaction of the Society.

4. IACS Procedure for Verification of Application of the PSPC

4.1 The verification requirements of section 7 of the PSPC shall be carried out by the Society.

4.1.1 Monitoring implementation of the coating inspection requirements, as called for in section 7.5 of the PSPC means checking, on a sampling basis, that the inspectors are using the correct equipment, techniques and reporting methods as described in the inspection procedures reviewed by the Society.

4.2 Any deviations found under 4.1.1 shall be raised initially with the coating inspector, who is responsible for identifying and implementing the corrective actions.

4.3 In the event that corrective actions are not acceptable to the Society or in the event that corrective actions are not closed out then the shipyard shall be informed.

4.4 A class certificate ~~is~~ shall not ~~to~~ be issued until all required corrective actions have been closed out to the satisfaction of the Society.

5. IACS Procedure for Coating Technical File Review

5.1 The shipyard is responsible for compiling the Coating Technical File (CTF) either in paper or electronic format, or a combination of the two.

5.2 The CTF is to contain all the information required by the PSPC section 3.4.

5.3 The CTF shall be reviewed for content in accordance with the PSPC section 3.4.2.

5.4 Any deviations found under 5.3 shall be raised with the shipyard, which is responsible for identifying and implementing the corrective actions.

**No.
34**
(cont'd)

5.5 A class certificate shall not be issued until all required corrective actions have been closed out to the satisfaction of the Society.

6. IACS Procedure for review of Quality Control of Automated Shop Primer plants

6.1 It is recognised that the inspection requirements of section 6.2 of the PSPC may be difficult to apply to an automated shop primer plant and a Quality Control approach would be a more practical way of enabling compliance with the requirements of PSPC.

6.2 As required in PSPC it is the responsibility of the coating inspector to confirm that the quality control procedures are ensuring compliance with PSPC.

6.3 When reviewing the Quality Control for automated shop primer plants the following procedures should be included.

6.3.1 Procedures for management of the blasting grit including measurement of salt and contamination.

6.3.2 Procedures recording the following; steel surface temperature, relative humidity, dewpoint.

6.3.3 Procedures for controlling or monitoring surface cleanliness, surface profile, oil, grease, dust and other contamination.

6.3.4 Procedures for recording/measuring soluble salts.

6.3.5 Procedures for verifying thickness and curing of the shop primer conforms to the values specified in the Technical Specification.

7. IACS Procedure for Review of Coating Technical Specifications

7.1 The coating technical specification should be provided by the shipyard in accordance with the requirements of PSPC detailing all the requirements of Table 1 of the PSPC.

7.2 The Coating Technical Specification should contain application procedure, acceptance criteria and inspection etc. as specified in paragraph 2 of Annex 1 of the PSPC.

7.3 When reviewing the technical specification for compliance with the requirements of PSPC the common interpretations in Annex 2 shall be used.

* * *

No. 34

(cont'd)

Annex 1 Work Procedures for Uniform Implementation of IMO PSPC by the EG/Coating

This procedure describes how members of the EG/Coating should deal with Q&As and requests for interpretations on matters relating to the IMO PSPC and IACS PR 34.

1. Definitions

Q&A	Questions and Answers
Common Interpretation (CI)	Explanation to achieve a common understanding of the requirements of the IMO PSPC
Unified Interpretation (UI)	As defined in IACS Procedures, section 15.2.3.
CSR KC DB	Knowledge Centre (KC) database consisting of Q&As, CIs and CSR Rule Change Proposals(RCP) (N.A. for the relevant Q&A and CI for IMO PSPC)
Initiator	Person, organization outside of the IACS, IACS Society or the EG/Coating itself who has raised questions, comments or requests for interpretation on the IMO PSPC and PR 34
Master file	A spreadsheet containing all the outcomes of questions raised by the EG/Coating (Q&A and CI for IMO PSPC)

For other definitions, refer to IACS Procedural Requirement (PR) No.32.

2. Roles of the EG/Coating and the CSR Secretariat

The EG/Coating is:

- To provide technical expertise and prepare technical answers and interpretations;
- To reply to the initiator with unanimously agreed technical answers, with a copy to the CSR Secretariat;
- To review and revise the scope and terms of reference of the IACS/Industry JWG/Coating and discuss with the JWG as necessary;
- To interact with the CSR Secretariat in administering Q&As and CIs on the web site;
- To keep PR 34 up-to-date incorporating the agreed Q&As and CIs as necessary (Ref.: Annex 2 to PR 34);
- To monitor the progress within the JWG/Coating and act as necessary; and
- To refer issues involving policy matters to GPG.

The CSR Secretariat is to provide administrative assistance to the work of the EG/Coating with a view to ensuring that Q&As and CIs are developed and published in a transparent and expeditious manner.

3. General Procedures for using the CSR KC DB

Despite the fact that the EG/Coating has a relatively limited role in maintaining the requirements of the Common Structural Rules (CSRs), full access to the KC DB is given to each member of the EG/Coating, so that a close link between the CSR PTs and the EG/Coating is established.

No. 34

(cont'd)

For Q&As and requests for CIs on the IMO PSPC that may affect the CSR implementation, e.g. scope of application of IMO PSPC under the CSR, they shall be entered into the KC DB and dealt with by appropriate work procedures.

The primary responsibility of dealing with this type of requests rests upon CSR PT 1 and PT 2 as appropriate, however, Permsec is to coordinate with the EG/Coating, when necessary, and ensure that information is exchanged between CSR PTs and the EG/Coating.

4. Work procedures

Unlike the CSR PTs, the EG/Coating is to conduct its day-to-day business via e-mail correspondence. The CSR Secretariat is to coordinate with the EG/Coating in data entry and publication.

4.1 Entry point

4.1.1 IACS Societies are to communicate directly with their respective EG/Coating members upon receipt of Questions and requests for CIs.

4.1.2 An initiator requesting Answer or CI may forward his/her request to IACS Societies or the CSR Secretariat.

4.1.3 Each member of the EG/Coating and the CSR Secretariat, upon receipt of a request, is to initiate discussion by the EG/Coating by e-mail correspondence.

4.2 Categorization

4.2.1 Each member of the EG, when initiating discussion, is to identify which category the request belongs to. The following categorization shall be used:

- Q&A: Question/Answers
- CI: Common Interpretation
- UI: Common interpretations that constitute Unified Interpretations on the requirements of the IMO PSPC. It shall be borne in mind that UIs shall be submitted, after completion of all processes as required by Annex 4.3 of the IACS Procedures, to IMO for consideration in due course.
- Amendments to PR 34: Outcomes that shall be incorporated into PR 34.

4.2.2 As time evolves, outcomes may need to be re-categorized from one to the other. The CSR Secretariat is responsible of ensuring that categorization of each outcome in the Master File is kept up-to-date.

4.3 Decision making

4.3.1 The Chair the EG/Coating is to strive for unanimous conclusions on the subjects under consideration and is to avoid voting wherever possible. However, repeated discussion shall be avoided on matters, where unanimous conclusions within the group is unlikely. In such cases the Chair of the EG/Coating is to finalize an issue on a two third majority basis at their level and forward it to GPG, together with identification and explanation of members' reservations (Ref: IACS Procedures, section 13.6).

4.3.2 GPG, upon receipt of a request from the EG for resolution, is to review and resolve the request within 10 working days.

4.3.3 The EG/Coating and the CSR Secretariat are to refer issues involving policy matters to GPG, and advise GPG on such policy issues when requested by GPG.

**No.
34**
(cont'd)**4.4 Notification and finalization**

4.4.1 Upon resolution of an issue, the EG/Coating is to notify the initiator with a copy to the CSR secretariat. The CSR Secretariat is then to update the Master file and post on the web site without delay.

4.4.2 The whole process from initiation to notification is, in general, to be completed within 10 working days.

5. PR 34 and UIs

The EG/Coating is to periodically update PR 34 incorporating the agreed Q&As and CIs as they deem it necessary.

In case where the EG/Coating finds it necessary to develop a UI on the IMO PSPC, the EG/Coating is to compile the information and develop a set of UIs for consideration by GPG. The UIs, when completed, shall be submitted to GPG for approval. (Ref: IACS Procedures, Annex 4.3)

6. Master file and public information

The CSR Secretariat is responsible for maintaining the Master file on the IACS web site on a daily basis incorporating the finalized Q&As and CIs.

No. 34
(cont'd)

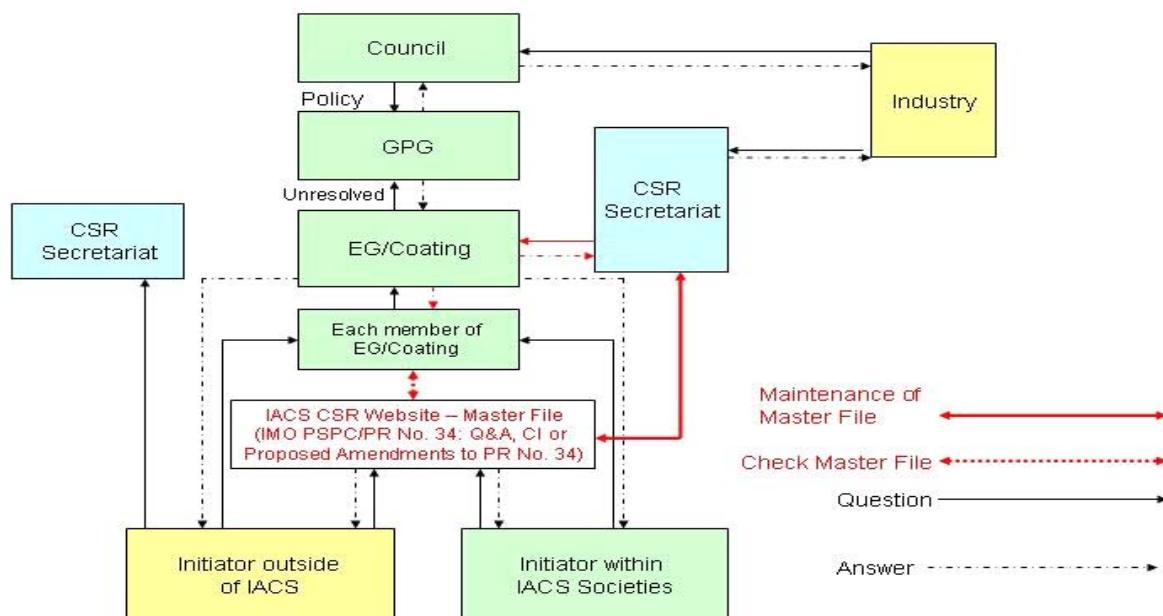

Figure 1 Flow chart

No.
34
(cont'd)

Annex 2 Unified Interpretations (Ref.: PR 34, 7.3, PR 34, Annex 1, para.2)

Unified Interpretations are listed hereunder in the order of the IMO PSPC Provisions.

Table 1-1.3, Coating pre-qualification test

1st para. reads: Epoxy-based system tested prior to the date of entry of this standard in a laboratory by a method corresponding to the test procedure in Annex 1 or equivalent, which as a maximum meets the requirements for rusting and blistering; or which have documented field exposure for 5 years with a final coating condition of not less than "GOOD" may be accepted.

Unified Interpretation

1. Winter type epoxy is required separate prequalification test including shop primer compatibility test according to Annex 1. Winter and summer type coating are considered different unless IR identification and SG demonstrates that they are the same.

Table 1-1.4, Selection of the coating system

1st para. reads: There shall be a minimum of two stripe coats and two spray coats, except that the second stripe coat, by way of welded seams only, may be reduced in scope where it is proven that the NDFT can be met by the coats applied in order to avoid unnecessary over thickness. Any reduction in scope of the second stripe coat shall be fully detailed in the CTF.

Unified Interpretations

1. Two stripe coats are also to be applied to all edges and all irregular welding beads. Where PSPC allows the second stripe coat to be dispensed with, the DFT measurement adjacent to the welds, not further than 15 mm from the welds, is acceptable. Statistical sampling measurement similar to Annex 3 for flat surface is acceptable for the verification of NDFT.
2. One stripe coat may also be applied in way of smooth automatic weld beads subject to confirmation that the NDFT has been achieved by thickness measurement of the coating after the second spray coat

Table 1-1.5, NDFT

3rd para reads: Care shall be taken to avoid increasing the thickness in an exaggerated way. Wet film thickness shall be checked during application.

Unified Interpretation

1. Wet film thickness shall be regularly checked during application for quality control by the Builder. PSPC does not state who should check WFT, it is accepted for this to be the Builder. DFT shall be done as part of the inspection section 6.

**No.
34**

(cont'd)

Table 1-3.3, Surface treatment after erection

It reads: Butts St 3 or better or Sa 2 ½ where practicable. Small damages up to 2% of total area: St 3. Contiguous damages over 25 m² or over 2% of the total area of the tank, Sa 2 ½ shall be applied.

Coating in overlap shall be feathered.

Unified Interpretation

1. Usually, the fillet welding on tank boundary watertight bulkhead is left without coating on block stage (because not yet be leakage tested), in which case it can be categorized as erection joint (“butt”) to be power tooling to St3.

Table 1-3.6, Water soluble salts limit equivalent to NaCl after blasting / grinding

It reads: “<= 50 mg/m² of sodium chloride”

Unified Interpretation

1. The value in mg/m² obtained from the test method 8502-9 shall be used without conversion, on the basis; All soluble salts have a detrimental effect on coatings to a greater or lesser degree. 8502-9 does not provide the actual concentration of NaCl. The % NaCl in the total soluble salts will vary from site to site. Minimum readings to be taken are one (1) reading per block/section/unit prior to applying coating or one (1) per plate in the case of manually applied shop primer. In cases where an automatic process for application of shop primer is used, there should be means to demonstrate compliance with PSPC through a Quality Control System, which should include a monthly test.

Table 1-4.3, Testing of coating

It reads: Dry film thickness shall be measured after each coat for quality control purpose and the total dry film thickness shall be confirmed after completion of final coat, using appropriate thickness gauges.

Unified Interpretation

1. All DFT measurements shall be measured and recorded. Only the final DFT measurements need to be measured and reported for compliance with the PSPC by the qualified coating inspector. The Coating Technical File may contain a summary of the DFT measurements which typically will consist of min / max DFT measurements, number of measurements taken and percentage above and below required DFT. The final DFT compliance with the 90/10 practice shall be calculated and confirmed, see PSPC 2.8.

**No.
34**

(cont'd)

Annex 3 Coating Manufacturer (Ref: PR 34, Method D, 1.18)**1. Coating Manufacturers**

1.1 Extent of Engagement – Production of coating systems in accordance with IMO Resolution MSC.215 (82) and IACS PR 34.

1.2 These requirements apply to both the main coating manufacturer and the shop primer manufacturer where both coatings form part of the total system.

1.3 The coating manufacturer should provide to the Society the following information;

- A detailed list of the production facilities.
- Names and location of raw material suppliers will be clearly stated.
- A detailed list of the test standards and equipment to be used, (Scope of approval).
- Details of quality control procedures employed.
- Details of any sub-contracting agreements.
- List of quality manuals, test procedures and instructions, records, etc.
- Copy of any relevant certificates with their issue number and/or date e.g. Quality Management System certification.

1.4 Inspection and audit of the manufacturer's facilities will be based on the requirements of the IMO Resolution MSC.215(82).

1.5 With the exception of early 'scale up' from lab to full production, adjustment outside the limitations listed in the QC instruction referred to below is not acceptable, unless justified by trials during the coating system's development programme, or subsequent testing. Any such adjustments must be agreed by the formulating technical centre.

1.6 If formulation adjustment is envisaged during the production process the maximum allowable limits will be approved by the formulating technical centre and clearly stated in the QC working procedures.

1.7 The manufacturer's quality control system will ensure that all current production is the same formulation as that supplied for the Type Approval Certificate. Formulation change is not permissible without testing in accordance with the test procedures in the IMO Resolution MSC.215(82) and the issue of a Type Approval Certificate by the Society.

1.8 Batch records including all QC test results such as viscosity, specific gravity and airless spray characteristics will be accurately recorded. Details of any additions will also be included.

1.9 Whenever possible, raw material supply and lot details for each coating batch will be traceable. Exceptions may be where bulk supply such as solvents and pre-dissolved solid epoxies are stored in tanks, in which case it may only be possible to record the supplier's blend.

1.10 Dates, batch numbers and quantities supplied to each coating contract will be clearly recorded.

2. All raw material supply must be accompanied the supplier's 'Certificate of Conformance'. The certificate will include all requirements listed in the coating manufacturer's QC system.

No.
34

(cont'd)

3. In the absence of a raw material supplier's certificate of conformance, the coating manufacturer must verify conformance to all requirements listed in the coating manufacturer's QC system.
4. Drums must be clearly marked with the details as described on the 'Type Approval Certificate'.
5. Product Technical Data Sheets must comply with all the PSPC requirements. The QC system will ensure that all Product Technical Data Sheets are current.
6. QC procedures of the originating technical centre will verify that *all* production units comply with the above stipulations and that all raw material supply is approved by the technical centre.

End of Document
